

STOVE MAINTENANCE

9. Reassemble stove. If stove performance is still impaired, repeat cleaning the jet and fuel line steps. It is complete.

Close Control Valve and remove Fuel Line. Safely dispose fuel when flushing ignition sources.

WARNING: Keep away from fire, burns, severe injury or death can occur. (jet unstalled.)

Insert Fuel Line into Pump and Fuel Bottle and secure Catch Arm on Fuel Pump Groove.

Pressurize Fuel Bottle with 15 strokes. Fully open Control Valve to flush 4 spoonfuls of fuel through Fuel Line into an appropriate container.

Remove Cable. Insert Fuel Line into Pump and Fuel Bottle Groove.

Remove Cable. Fully reinsert Cable into Fuel Line. Wipe Cable clean. (1.3-cm) strokes approximately 20 times. Move Cable in and out with 5-inch Jet and Cable Tool. Subborn cables can be loosened with a common lubricant (WD-40™, Pump Cup Oil, etc.).

Remove Cable from Fuel Line with Jet and Cable Tool. Clear Jet Orifice.

6. Remove Shaker Needle and use it to clear Jet Orifice from top or bottom. NOTE: To exchange jets, place Shaker Needle in new jet and reassemble stove. annually, or every time you perform the Pump Maintenance.

Deposits in the jet and fuel line reduce fuel flow and impair stove performance. Minor deposits in the jet can be cleared with the Shaker Needle. Major deposits may require extensive cleaning of the jet and fuel line. At a minimum, perform the following maintenance:

CLEANING THE JET WITH THE SHAKER NEEDLE

1. Close Pump Control Valve and wait 5 minutes for stove to cool.
2. Shake stove up and down.
3. Preheat and run stove. Shaker Needle inside jet should rattle. If performance does not improve, perform cleaning the jet and fuel line steps.

CLEANING THE JET AND FUEL LINE

1. Fold Pot Supports/Legs to packed position.
2. Unscrew Priming Cup and remove Wick.
3. Hold folded Pot Supports/Legs together. Remove Fuel Line from Mixer Tube.
4. Unscrew Jet with Jet and Cable Tool. IMPORTANT: Do not bend Generator Tube while loosening jet.

Remove Jet. Shake the Stove. Unscure Priming Cup.

8. Flush Fuel Line. Wipe Cable clean. (1.3-cm) strokes approximately 20 times. Move Cable in and out with 5-inch Jet and Cable Tool. Subborn cables can be loosened with a common lubricant (WD-40™, Pump Cup Oil, etc.). Fully reinsert Cable into Fuel Line. Insert Fuel Line into Pump and Fuel Bottle and secure Catch Arm on Fuel Pump Groove. Pressurize Fuel Bottle with 15 strokes. Fully open Control Valve to flush 4 spoonfuls of fuel through Fuel Line into an appropriate container. Safely dispose fuel when flushing ignition sources. Close Control Valve and remove Fuel Line. Reassemble stove. If stove performance is still impaired, repeat cleaning the jet and fuel line steps.

7. Scour Fuel Line. Remove Cable from Fuel Line with Jet and Cable Tool. Subborn cables can be loosened with a common lubricant (WD-40™, Pump Cup Oil, etc.). Fully reinsert Cable into Fuel Line. Move Cable in and out with 5-inch (1.3-cm) strokes approximately 20 times. Wipe Cable clean.

5. Insert Plunger. Hold thumb and forefinger firmly around Arrow 1. Align Plunger Bushing Tabs with holes in Pump Body. Push Plunger/Bushing into the Pump Body until it snaps in place.

4. Lubricate Pump Cup. Use a drop of Pump Cup Oil or any mineral-based oil. If needed, a spare red Fuel Tube O-ring is provided.

3. Inspect O-ring and replace if damaged. Remove the O-ring with the end of the Fuel Line or Safety Pin.

2. Remove Fuel Tube Bushing and O-ring with Jet and Cable Tool. Align, twist, and pull.

1. Remove Plunger.

PUMP MAINTENANCE

REPLACING CONTROL VALVE O-RING

1. Unscrew Stop Nut 2 turns.
2. Unscrew Control Valve 6 turns.
3. Unscrew Stop Nut completely and remove Control Valve Assembly.
4. Inspect O-ring and replace if damaged.

Remove Control Valve handle from stem. Remove O-ring with Safety Pin.

REPLACING PUMP SEAL

Inspect Pump Seal and replace if damaged.

CLEANING THE CHECK VALVE

1. Turn Check Valve Assembly to remove. Wipe any debris from Check Valve and Pump Cavity.
2. Reinsert Check Valve Assembly.

Remove Valve Assembly.

Remove/Replace Pump Seal

Unscrew Stop Nut.

REPLACING FUEL TUBE O-RING

O-rings can become dry, cracked or torn with use. Their lifespan is affected by dirt, debris, temperature, friction and frequency of use. For this reason, please inspect your O-rings before every trip. Replace dry, cracked, or torn O-rings immediately, regardless of appearance. Replacement O-rings and Pump Seals can be found in the Annual Maintenance Kit, or the more comprehensive Expedition Service Kit, purchased separately from an MSR® dealer.

1. Remove Plunger. Align, twist, and pull.

2. Remove Fuel Tube Bushing and O-ring with Jet and Cable Tool. Remove the O-ring with the end of the Fuel Line or Safety Pin.

3. Inspect O-ring and replace if damaged. If needed, a spare red Fuel Tube O-ring is provided.

4. Lubricate Pump Cup. Use a drop of Pump Cup Oil or any mineral-based oil.

5. Insert Plunger. Hold thumb and forefinger firmly around Arrow 1. Align Plunger Bushing Tabs with holes in Pump Body. Push Plunger/Bushing into the Pump Body until it snaps in place.

WARNING

Do not disassemble stove or pump beyond what is described in these instructions. Disassembly or modification of stove or pump in any manner not consistent with these instructions voids warranty and can result in an unsafe situation where fire, burns, severe injury or death can occur.

Do not use stove or pump if parts are missing or broken, or with replacement parts not specific to your stove model. Use Do not use stove or pump if parts are missing or broken, or with replacement parts not specific to your stove model. Use

TROUBLESHOOTING

Problem	Cause	Solution
Leaking Fuel		
At Pump and Fuel Bottle Connection	Damaged or missing Pump Seal	Replace Pump Seal
At Pump and Fuel Line Connection	Damaged or missing Fuel Tube O-ring	Replace Fuel Tube O-ring
At Control Valve Stem	Damaged or missing Control Valve O-ring	Replace Control Valve O-ring
In Pump Plunger Chamber	Obstructed Check Valve	Clean Check Valve Cavity
Poor Performance		
Pump not pressurizing Fuel Bottle	Loose or poorly seated Pump	Tighten or rescure Pump on Fuel Bottle
	Damaged Pump Cup	Replace Pump Cup
Plunger hard to pump	Dry Pump Cup	Lubricate Pump Cup
Erratic yellow flames	Improper preheating	Repeat Step 4
Diminished flames	Low Fuel Bottle pressure	Pump the Plunger
Slow boil times	Clogged Jet or Fuel Line	Clear Jet and clean Fuel Line
Diminished flames at altitude	Insufficient airflow	Open Windscreen slightly

FUEL INFORMATION

The WhisperLite™ Internationale stove burns a variety of fuels by using two interchangeable Jets.

1. The UG Jet is used for White Gas and Unleaded Auto Gas. This Jet is preinstalled in your stove.
2. The UK Jet is for Kerosene. This Jet is included in the parts kit with your stove. To exchange Jets, see "Cleaning the Jet and Fuel Line."

Use MSR® SuperFuel™ (White Gas) for optimal performance. It is the highest quality fuel available for your stove. Do not use leaded fuels. Fuels other than MSR SuperFuel white gas lead to rapid stove clogging and require more frequent Jet and Fuel Line cleanings. Also, the use of Unleaded Auto Gas may shorten stove lifespan. Use the fuels chart below to help you find your fuel when traveling internationally.

Visit www.msrgear.com for more information on international fuel names and safe stove transportation.

USA/UK/Canada	Germany/Switzerland	Japan	France	Netherlands	Spain
White Gas, Naphtha	Kocherbenzin, Reinbenzin	White Gas	Pétrole à brûler, Essence C	Wasbenzine	Bencina blanca
Unleaded Auto Gas	Autobenzin	Gasoline	Essence sans plomb	Benzine	Gasolina sin plomo
Kerosene	Petroleum	Toh-yu	Kérosène	Petroleum Lampolie	Parafina

DANGER

CARBON MONOXIDE HAZARD

This stove produces carbon monoxide, which has no odor. Using it in an enclosed space can kill you. Never use this stove in an enclosed space such as a camper, tent, car, or home.

FOR YOUR SAFETY

Do not store or use gasoline or other liquids with flammable vapors in the vicinity of this or any other stove.

DANGER

CARBON MONOXIDE, FIRE & EXPLOSION HAZARD

There are serious hazards associated with using this stove and fuel. Accidental fire, explosion, and misuse can cause death, serious burns, and property damage. You are responsible for your own safety and the safety of those in your group. Please use good judgment.

This stove is for OUTDOOR USE ONLY. Never use this stove in a tent, vestibule, car, house, or inside any enclosed area. This stove consumes oxygen and produces carbon monoxide gas, which is poisonous and has no odor. This stove can easily ignite nearby combustible materials and flammable liquids or vapors. If you use this stove in an enclosed area you can be killed or seriously burned.

Keep stove and fuel bottle away from other heat sources. Never use cookware or an Outback Oven™ with a diameter larger than 10 inches (25 centimeters). Oversized cookware can overheat the fuel bottle. If you expose the fuel bottle to high heat, it will explode and you can be killed or seriously burned.

Never let children use this stove. Keep children at least 10 feet (3 m) away from the stove and cooking area, and supervise them at all times.

INSTRUCTION MANUAL

MSR
MOUNTAIN SAFETY RESEARCH®

WHISPERLITE™ INTERNATIONAL

Retain these instructions for future reference.

FOR OUTDOOR USE ONLY

For product service and information contact
Cascade Designs, Inc.
 4000 First Avenue South, Seattle, WA 98134 USA
 Phone: 800.531.9531 or 206.505.9500
www.msrgear.com

ART# 33-385 | EN

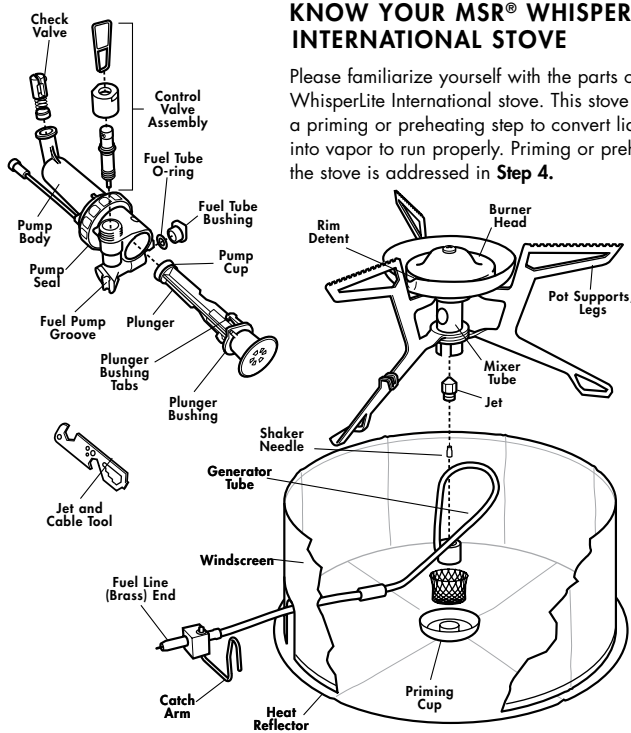

KNOW YOUR MSR® WHISPERLITE™ INTERNATIONAL STOVE

Please familiarize yourself with the parts of your WhisperLite International stove. This stove requires a priming or preheating step to convert liquid fuel into vapor to run properly. Priming or preheating the stove is addressed in **Step 4**.

WARNING

Do not use this stove: (1) before reading and fully understanding this Instruction Manual; (2) if you are not prepared or comfortable attending to a burning and/or hot stove at all times; (3) if you observe leaking fuel; or (4) if you observe any condition with the stove system or in the surrounding environment that would make operation of an open flamed device dangerous. Failure to follow these directions can cause an unsafe situation leading fire, burns, severe injury or death.

WHISPERLITE™ INTERNATIONAL STOVE OPERATING INSTRUCTIONS

To avoid being killed or seriously injured, **READ, UNDERSTAND, AND FOLLOW ALL** instructions and warnings in this manual before using this stove.

1 PREPARE FUEL BOTTLE

The WhisperLite International stove is sold with two interchangeable Jets so it can burn a variety of fuels. To ensure the correct Jet is installed for the type of fuel to be used, see *Fuel Information*.

1. **Fill Fuel Bottle to fill line only.**
Air space is necessary for fuel expansion.
2. **Insert Pump into Fuel Bottle and firmly tighten.**
3. **Check Fuel Bottle for leaks before pressurizing bottle.**
4. **Close the Pump Control Valve, then stroke Plunger (20-30 strokes).**
Pump until firm resistance is felt.
Less fuel requires more strokes or pressure.

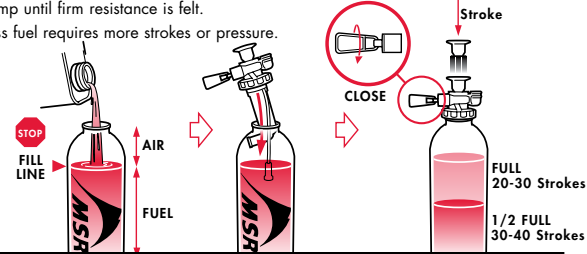

WARNING

Use MSR® fuel bottles only. Non-MSR fuel bottles may leak fuel creating an unsafe situation leading to fire, burns, severe injury or death.
Keep children far away from stove and fuel—Cascade Designs, Inc. recommends no less than 10 feet (3+ meters). Never leave a burning or hot stove unattended. An unattended stove can lead to fire and/or a situation where children, pets, or the unwary can be burned, injured, or killed.
Use extreme caution when using stove in temperatures below freezing. In freezing temperatures O-rings can stiffen and leak fuel. Always check for fuel leaks before and after pressurizing bottle, priming, and during and after lighting stove. Use of a leaking stove can cause fire, burns, severe injury or death.

2 SET UP STOVE

1. **Unfold the 3 Pot Supports/Legs.**
Rotate Pot Supports/Legs fully open.
2. **Place stove on the center of Heat Reflector.**

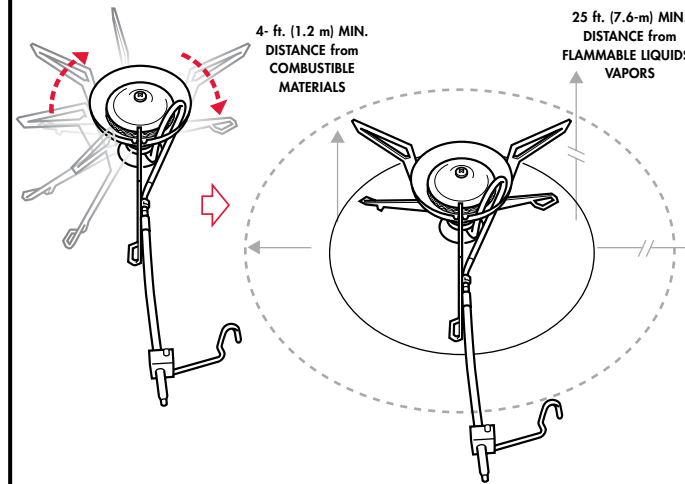

WARNING

Keep combustibles at least 4 feet (1.2 meters) away from the top and sides of a burning stove, or a stove that you are in the process of lighting. Keep flammable liquids and vapors at least 25 feet (7.6 meters) away from the top and sides of a burning stove, or a stove that you are in the process of lighting. This stove can ignite combustible materials, flammable liquids and vapors creating a situation where fire, burns, severe injury or death can result.
This stove is designed for the outside (i.e., not within enclosure spaces of any kind; e.g., tents) boiling of water or cooking of food only—never use it for any other purpose. Use of stove within any enclosure, or for a purpose other than boiling water or cooking food can cause fire, burns, severe injury or death.

3 CONNECT STOVE AND PUMP

1. **Lubricate the entire brass end of the Fuel Line with saliva or oil.**
2. **Completely insert the brass end of the Fuel Line into Pump.**
Place Fuel Bottle on its side so Pump Control Valve points up.
3. **Secure the Catch Arm on Fuel Pump Groove.**
Keep Fuel Line straight for safety.
Keep Fuel Bottle as far away from stove as possible.

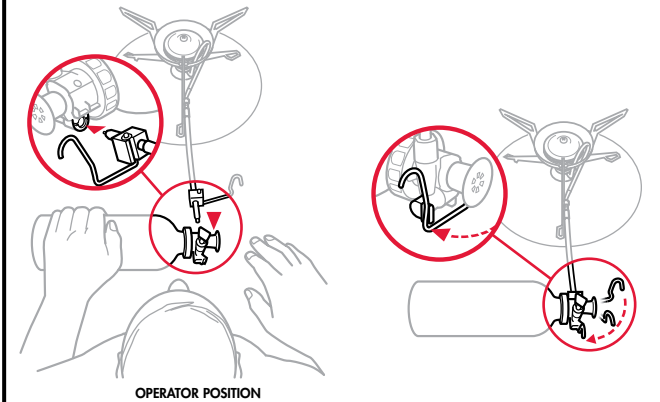

WARNING

Before every use, look for fuel on the fuel bottle, pump, fuel line, burner, and on the area beneath and around stove. Do not light stove if you see or smell fuel. See *Troubleshooting*. Use of stove where fuel has leaked and/or is leaking can cause fuel to ignite causing fire, burns, severe injury or death.
Never disconnect the fuel line, pump, or fuel bottle when stove is burning, hot, or near any open flame. Never disconnect fuel line, pump, or fuel bottle when stove is burning, hot, or near any open flame, or disconnecting fuel line, pump, or fuel bottle when control valve is in an open (i.e., fuel flowing) position. Disconnecting fuel line, pump, or fuel bottle when control valve is in an open (i.e., fuel flowing) position can lead to spilled fuel that can ignite and cause fire, burns, severe injury or death.

4 PREHEAT STOVE

1. **Release only 1/2 spoonful of fuel.**
Open Pump Control Valve 3/4 turn and let fuel flow through the Jet.
Close Pump Control Valve.
Look for fuel in Priming Cup and on Wick.
2. **Light fuel in the Priming Cup.**
A brief soccer ball size flame is normal.

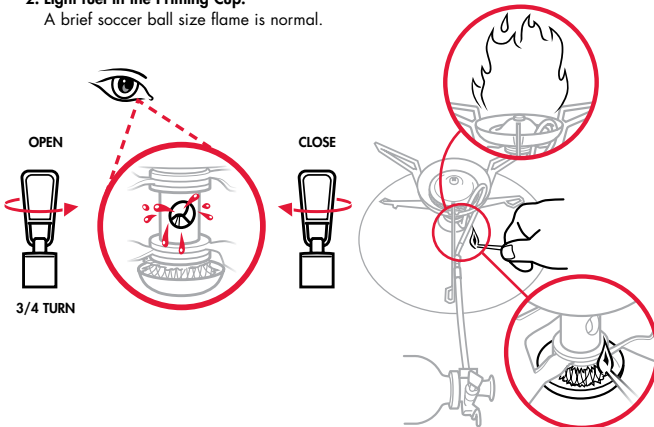

WARNING

Never place your head or body above the stove while priming, lighting, or cooking. Because stove maintains an open flame, placement of head or body above stove is an unsafe practice that can cause fire, burns, severe injury or death.
Never use excess fuel to preheat stove. Use of excess fuel for priming can lead to leaking or spilled fuel that can cause fire, burns, severe injury or death.

5 TURN STOVE ON

1. **Wait for preheat flame to reduce in size (approximately 2 minutes).**
If flame goes out, wait 5 minutes for stove to cool before relighting.
2. **Open Pump Control Valve 1/2 turn and wait for steady blue flame.**
3. **Slowly open Pump Control Valve.**

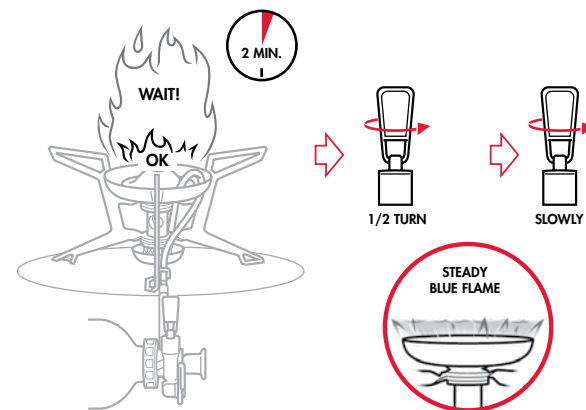

WARNING

Never relight a heated stove. Always let an extinguished stove cool for at least 5 minutes before relighting. Relighting a heated stove can cause large flames that can cause fire, burns, severe injury or death.
Never move a burning or hot stove. Always extinguish stove and cool for at least 5 minutes before moving. Moving a burning or hot stove can cause fire, burns, severe injury or death.

6 USE STOVE TO COOK

1. **Set up Windscreen.**
Fold the ends of Windscreen together.
Leave a 1-inch (2.5 cm) gap between Windscreen and pot for optimal performance.
Ensure that combustion flow and ventilation air are free of any obstruction.
Use Windscreen to improve performance in all conditions.
2. **Add appropriate food or liquid to cookware and place on center of stove.**
3. **Maintain Fuel Bottle pressure.**
Add approximately 10 strokes every 10 minutes to maintain performance.
Hold Fuel Bottle firmly while pumping.

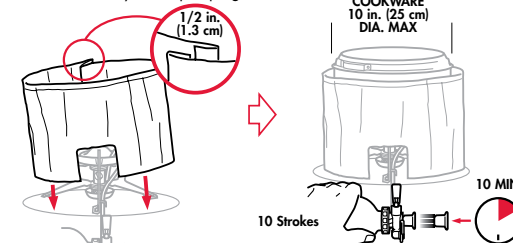

WARNING

Keep fuel bottle away from the stove burner and other heat sources. Position connected fuel bottle so that it is as far away from the burner as possible. Use of bottle near burner or other heat sources can result in the fuel bottle exploding and causing fire, burns, severe injury or death.
Never place windscreen around fuel bottle. Never use cookware with a diameter greater than 10 inches (25 centimeters). Never place and operate two or more stoves together. Never operate stove with empty or dry cookware. Never use non-MSR® reflectors or diffusers. Use of stove in any of the proceeding manners can result in the fuel bottle exploding and causing fire, burns, severe injury or death.
Never use cookware of any size that is ill-suited and/or inappropriate for use with stove, particularly stove pot supports (e.g., cookware with a convex or concave bottom, some enameled cookware, etc.). Use of stove with ill-suited and/or inappropriate cookware can result in cookware and/or stove instability and a situation where hot cookware and/or cookware contents can spill and cause fire, burns, severe injury or death. Cascade Designs, Inc. warrants the use of appropriately sized MSR® brand cookware only—use of cookware other than MSR® brand cookware will be at user's own risk and discretion.

7 TURN STOVE OFF

1. **Close Pump Control Valve.**
Residual fuel will continue to burn with a small flame.
2. **After flames are out, wait 5 minutes for stove to cool.**
3. **Unlock Catch Arm and remove Fuel Line from Pump.**
4. **Depressurize Fuel Bottle and repack stove.**
Hold the Fuel Bottle upright, away from your face and any sources of heat or ignition.
Slowly unscrew pump to depressurize Fuel Bottle.

NOTICE: To transport the Fuel Bottle, the Pump may be left inside a depressurized Fuel Bottle. The Pump can also be removed and replaced with the Fuel Bottle Cap.

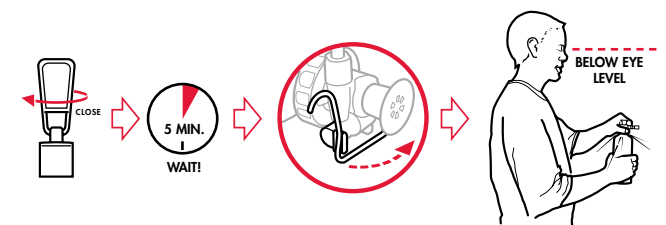

WARNING

Always store fuel bottle with cap securely tightened where it cannot be accessed by children. Storage of fuel bottle with loose cap and/or where accessible by children can result in a child obtaining possession of fuel bottle and accessing bottle contents. Exposure to bottle contents topically and/or by ingestion can cause poisoning, severe injury, or death.
Always store fuel bottle in a well-ventilated location away from any possible heat or ignition source such as: water heaters, stoves, pilot lights, or furnaces. Storing bottle near any heat or ignition source can result in the fuel bottle exploding and causing fire, burns, severe injury or death.