

STOVE MAINTENANCE

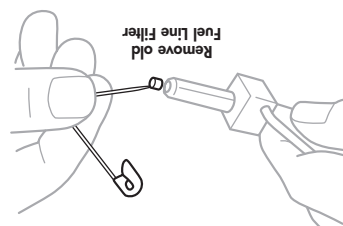

- Remove old fuel line filter with Safety Pin.
- Place new white fuel line filter on a hard surface.

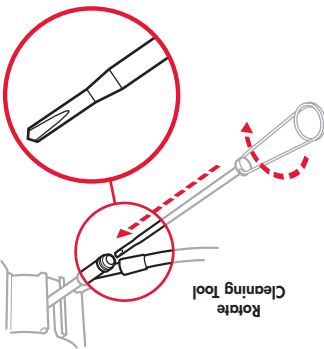

- Put flame adjuster handle onto dragonfly cleaning tool.
- Insert tool into flame adjuster tube and rotate clockwise with pressure (approximately 20 turns).
- Top flame adjuster tube on a hard surface to remove loosened deposits.
- Reinsert flame adjuster valve assembly and tighten securely.
- Flush the fuel line.
- Connect stove to pump and fuel bottle.
- Pressurize fuel bottle with 10-15 strokes.
- Fully open pump control valve and flame adjuster valve to flush 4 spoonfuls of fuel through fuel line into an appropriate container. (Jet unstalled.)
- WARNING: Keep away from ignition sources.
- Close and reopen flame adjuster valve to repeat flushing.
- Close flame adjuster valve and pump control valve and remove fuel line.
- Safely dispose fuel when flushing is complete.
- Reassemble stove.
- If stove performance is still impaired, repeat cleaning the jet and flame adjuster assembly steps.

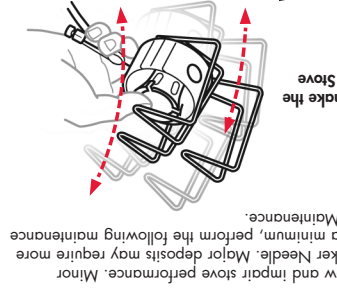
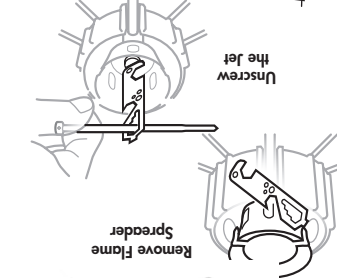
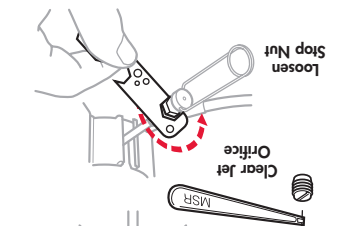

- Close pump control valve and wait 5 minutes for stove to cool.
 - Shake stove up and down.
 - Preheat and run stove.
- If performance does not improve, perform cleaning the jet and flame adjuster valve assembly steps.
- Shaker Needle inside jet should rotate.

- Close pump control valve and wait 5 minutes for stove to cool.
- Shake stove up and down.
- Preheat and run stove.
- Remove flame spreader.
- Unscrew jet with jet and cable tool.
- Use dragonfly cleaning tool with jet needle in new jet and reassemble stove.
- Remove shaker needle.
- NOTE: To exchange jets, place shaker needle in new jet and reassemble stove.
- Open flame adjuster valve 2 turns.
- Loosen stop nut with jet and cable tool.
- Unscrew flame adjuster valve completely.
- Remove flame adjuster valve assembly.
- Clean grooved end of flame adjuster with thumb nail or jet cleaning wire.

PUMP MAINTENANCE

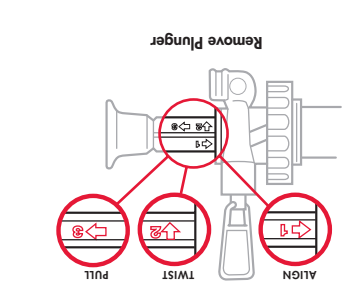
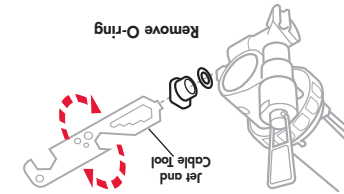
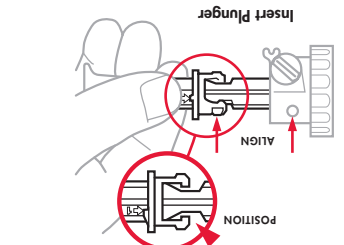

- Remove plunger.
 - Align, twist, and pull.
 - Remove O-ring.
 - Align, twist, and pull.
 - Remove fuel tube bushing and O-ring with jet and cable tool.
 - Remove the O-ring with the end of the fuel line or safety pin.
 - Inspect O-ring and replace if damaged. If needed, a spare green fuel tube lubricate pump cup.
 - Use a drop of pump cup oil or any mineral-based oil.
 - Hold thumb and forefinger firmly around plunger 1.
 - Align plunger bushing tabs with holes in pump body.
 - Push plunger/bushing into the pump body until it snaps in place.
- O-rings can become dry, cracked or torn with use. Their lifespan is affected by dirt, debris, temperature, friction and frequency of use. For this reason, please inspect your O-rings before every trip. Replace dry, cracked, or torn O-rings immediately, and replace all O-rings annually, regardless of appearance. Replacement O-rings and pump seals can be found in the Annual Maintenance Kit, or the more comprehensive Expedition Service Kit, purchased separately from an MSR® dealer.

WARNING

Do not disassemble stove or pump beyond what is described in these instructions. Disassembly or modification of stove or pump in any manner not consistent with these instructions voids warranty and can result in an unsafe situation where fire, burns, severe injury or death can occur. Do not use stove or pump if parts are missing or broken, or with replacement parts not specific to your stove model. Use of stove with missing or broken parts, or with replacement parts not specific to your stove model, can result in an unsafe situation where fire, burns, severe injury or death can occur.

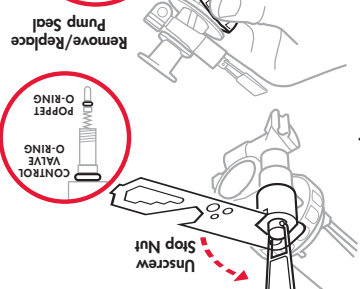

- Unscrew stop nut 2 turns.
- Unscrew pump control valve 6 turns.
- Unscrew stop nut completely and remove control valve assembly.
- Inspect O-rings and replace if damaged.
- Remove pump control valve handle from stem.
- Slide stop nut off.
- Remove O-ring(s) with safety pin.
- Inspect pump seal and replace if damaged.
- Wipe any debris from check valve.
- Turn check valve assembly to remove.
- Reinsert check valve assembly.

STOVE MAINTENANCE

DANGER



CARBON MONOXIDE HAZARD

This stove produces carbon monoxide, which has no odor. Using it in an enclosed space can kill you. Never use this stove in an enclosed space such as a camp, tent, car, or home.

FOR YOUR SAFETY

Do not store or use gasoline or other liquids with flammable vapors in the vicinity of this or any other stove.

DANGER



CARBON MONOXIDE, FIRE & EXPLOSION HAZARD

There are serious hazards associated with using this stove and fuel. Accidental fire, explosion, and misuse can cause death, serious burns, and property damage. You are responsible for your own safety and the safety of those in your group. Please use good judgment.

This stove is for OUTDOOR USE ONLY. Never use this stove in a tent, vestibule, car, house, or inside any enclosed area. This stove consumes oxygen and produces carbon monoxide gas, which is poisonous and has no odor. This stove can easily ignite nearby combustible materials and flammable liquids or vapors. If you use this stove in an enclosed area you can be killed or seriously burned.

Keep stove and fuel bottle away from other heat sources. Never use cookware or an Outback Oven™ with a diameter larger than 10 inches (25 centimeters). Oversized cookware can overheat the fuel bottle. If you expose the fuel bottle to high heat, it will explode and you can be killed or seriously burned.

Never let children use this stove. Keep children at least 10 feet (3 m) away from the stove and cooking area, and supervise them at all times.

TROUBLESHOOTING

Problem	Cause	Solution
Leaking Fuel		
At Pump and Fuel Bottle Connection	Damaged or missing Pump Seal	Replace Pump Seal
At Pump and Fuel Line Connection	Damaged or missing Fuel Tube O-ring	Replace Fuel Tube O-ring
At Control Valve Stem	Damaged or missing Control Valve O-ring	Replace Control Valve O-ring
In Pump Plunger Chamber	Obstructed Check Valve	Clean Check Valve Cavity
Poor Performance		
Pump not pressurizing Fuel Bottle	Loose or poorly seated Pump on Fuel Bottle	Tighten or rescrew Pump on Fuel Bottle
	Damaged Pump Cup	Replace Pump Cup
Plunger hard to pump	Dry Pump Cup	Lubricate Pump Cup
Erratic yellow flames	Improper preheating	Repeat Step 4
Diminished flames	Low Fuel Bottle pressure	Pump the Plunger
Slow boil times	Clogged Jet or Fuel Line	Clear Jet and clean Fuel Line
Diminished flames at altitude	Insufficient airflow	Open Windscreen slightly

FUEL INFORMATION

The DragonFly® stove burns a variety of fuels by using two interchangeable Jets.

- The DG Jet is used for White Gas and Unleaded Auto Gas. This Jet is preinstalled in your stove.
- The DK Jet is for Kerosene, Diesel, and Jet Fuel. This Jet is included in the parts kit with your stove. To exchange jets, see "Cleaning the Jet and Flame Adjuster Valve Assembly."

Use MSR® SuperFuel™ (White Gas) for optimal performance. It is the highest quality fuel available for your stove. Do not use leaded fuels. Fuels other than MSR SuperFuel white gas lead to rapid stove clogging and require more frequent Jet and Fuel Line cleanings. Also, the use of Unleaded Auto Gas may shorten stove lifespan. Use the fuels chart below to help you find your fuel when traveling internationally.

Visit www.msrgear.com for more information on international fuel names and safe stove transportation.

USA/UK/Canada	Germany/Switzerland	Japan	France	Netherlands	Spain
White Gas, Naphtha	Kocherbenzin, Reinbenzin	White Gas	Pétrole à brûler, Essence C	Wasbenzine	Bencina blanca
Unleaded Auto Gas	Autobenzin	Gasoline	Esence sans plomb	Benzine	Gasolina sin plomo
Kerosene	Petroleum	Toh-yu	Kérosène	Petroleum Lampolie	Parafina
Diesel	Diesel	Diesel	Diesel	Diesel	Diesel

READ, UNDERSTAND, AND FOLLOW ALL instructions and warnings in this manual before using this stove. Failure to follow warnings and instructions can result in death, serious burns or other injury, and property damage.

FOR OUTDOOR USE ONLY



For product service and information contact

Cascade Designs, Inc.

4000 First Avenue South, Seattle, WA 98134 USA

Phone: 800.531.9531 or 206.505.9500

www.msrgear.com

ART# 33-305-2 | EN

INSTRUCTION MANUAL



MSR
MOUNTAIN SAFETY RESEARCH®

DRAGONFLY®

Retain these instructions for future reference.

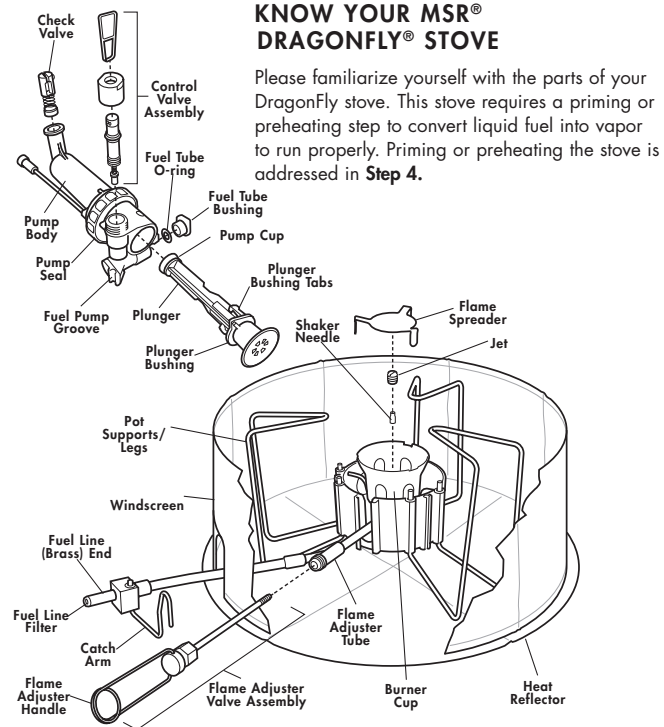

WARNING

Do not use this stove: (1) before reading and fully understanding this Instruction Manual; (2) if you are not prepared or comfortable attending to a burning and/or hot stove at all times; (3) if you observe leaking fuel; or (4) if you observe any condition with the stove system or in the surrounding environment that would make operation of an open flamed device dangerous. Failure to follow these directions can cause an unsafe situation leading fire, burns, severe injury or death.

DRAGONFLY® STOVE OPERATING INSTRUCTIONS
To avoid being killed or seriously injured, READ, UNDERSTAND, AND FOLLOW ALL instructions and warnings in this manual before using this stove.

1 PREPARE FUEL BOTTLE

The DragonFly stove is sold with two interchangeable Jets so it can burn a variety of fuels. To ensure the correct Jet is installed for the type of fuel to be used, see *Fuel Information*.

1. **Fill Fuel Bottle to fill line only.**
Air space is necessary for fuel expansion.
2. **Insert Pump into Fuel Bottle and firmly tighten.**
3. **Check Fuel Bottle for leaks before pressurizing the bottle.**
4. **Close the Pump Control Valve, then stroke Plunger (20-30 strokes).**
Less fuel requires more strokes or pressure. Pump until firm resistance is felt.

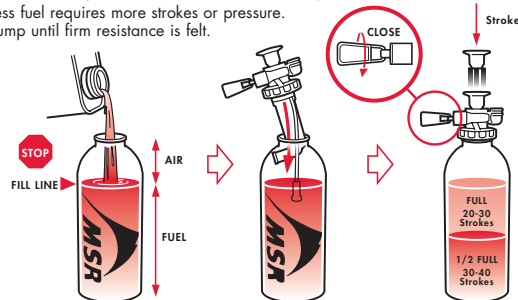

WARNING

Use MSR® fuel bottles only. Non-MSR® fuel bottles may leak fuel creating an unsafe situation leading to fire, burns, severe injury or death. Keep children far away from stove and fuel—Cascade Designs, Inc. recommends no less than 10 feet (3+ meters). Use extreme caution when using stove in temperatures below freezing. In freezing temperatures O-rings can stiffen and leak fuel. Always check for fuel leaks before and after pressurizing bottle, priming, and during and after lighting stove. Use of a leaking stove can cause fire, burns, severe injury or death.

2 SET UP STOVE

1. **Open the 3 sets of Pot Supports/Legs.**
2. **Rotate the Burner and Fuel Line Assembly into position.**
3. **Unfold the Flame Adjuster Valve Assembly.**
Close the Flame Adjuster Valve.
4. **Place stove on the center of Heat Reflector.**

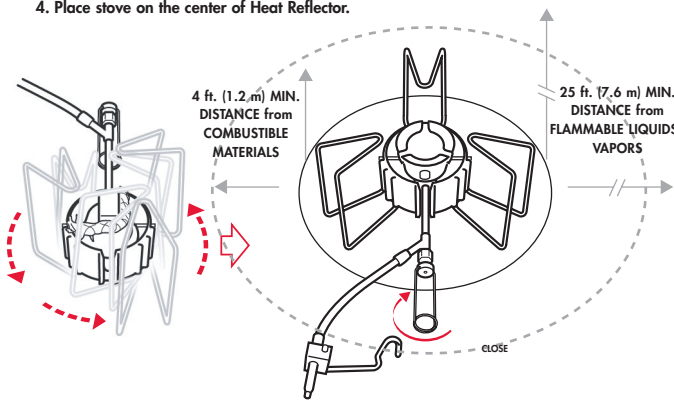

WARNING

Keep combustibles at least 4 feet (1.2 meters) away from the top and sides of a burning stove, or a stove that you are in the process of lighting. Keep flammable liquids and vapors at least 25 feet (7.6 meters) away from the top and sides of a burning stove, or a stove that you are in the process of lighting. This stove can ignite combustible materials, flammable liquids and vapors creating a situation where fire, burns, severe injury or death can result. This stove is designed for the outside (i.e., not within enclosed spaces of any kind; e.g., tents) boiling of water or cooking of food only—never use it for any other purpose. Use of stove within any enclosure, or for a purpose other than boiling water or cooking food can cause fire, burns, severe injury or death. Always use stove on a solid, stable, even surface to avoid tipping and spills. Tipping of stove can result in an unsafe situation where fire, burns or severe injury or death can occur.

3 CONNECT STOVE AND PUMP

1. **Lubricate the entire brass end of the Fuel Line with saliva or oil.**
2. **Completely insert the brass end of the Fuel Line into Pump.**
Place Fuel Bottle on its side so Pump Control Valve points up.
3. **Secure the Catch Arm on Fuel Pump Groove.**
Gently bend Fuel Line straight for safety. Keep Fuel Bottle as far away from stove as possible.

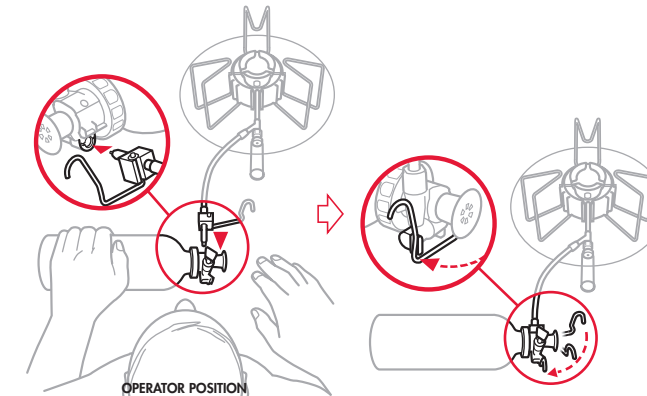

WARNING

Before every use, look for fuel on the fuel bottle, pump, fuel line, burner, and on the area beneath and around stove. Do not light stove if you see or smell fuel. See Troubleshooting. Use of stove where fuel has leaked and/or is leaking can cause fuel to ignite causing fire, burns, severe injury or death. Never disconnect the fuel line, pump, or fuel bottle when stove is burning, hot, or near any open flame. Never disconnect fuel line, pump, or fuel bottle when control valve is in an open (i.e., fuel flowing) position. Disconnecting fuel line, pump, or fuel bottle when stove is burning, hot, or near any open flame, or disconnecting fuel line, pump, or fuel bottle when control valve is in an open (i.e., fuel flowing) position can lead to spilled fuel that can ignite and cause fire, burns, severe injury or death.

4 PREHEAT STOVE

1. **Turn the Pump Control Valve fully open on Fuel Bottle.**
2. **Release only 1/2 spoonful of fuel.**
Open Flame Adjuster Valve and let fuel flow through the Jet.
3. **Close the Flame Adjuster Valve.**
4. **Light the priming fuel on the Wick.**
A brief soccer ball size flame is normal.

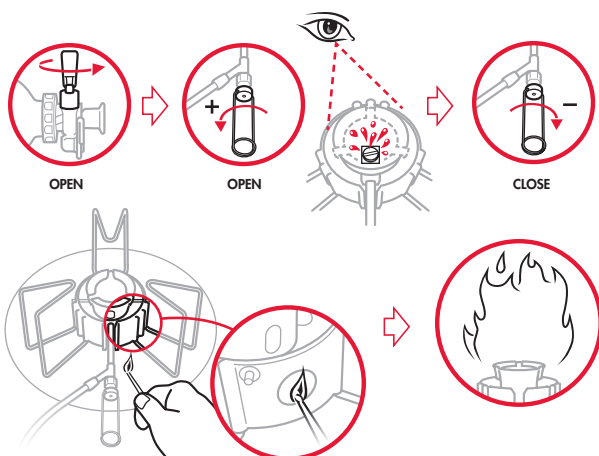

WARNING

Never place your head or body above the stove while priming, lighting, or cooking. Because stove maintains an open flame, placement of head or body above stove is an unsafe practice that can cause fire, burns, severe injury or death. Never use excess fuel to preheat stove. Use of excess fuel for priming can lead to leaking or spilled fuel that can cause fire, burns, severe injury or death.

5 TURN STOVE ON

1. **Wait for preheat flame to reduce in size (approximately 2 minutes).**
If flame goes out, wait 5 minutes for stove to cool before relighting.
2. **Open Flame Adjuster Valve 1/2 turn and wait for steady blue flame.**
3. **Slowly open Flame Adjuster Valve to increase fuel and heat.**

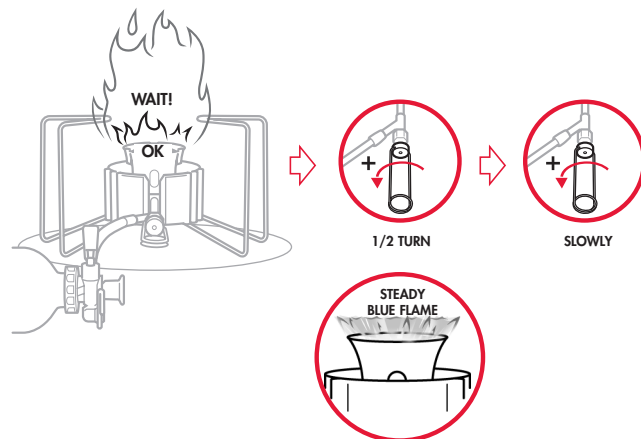

WARNING

Never relight a heated stove. Always let an extinguished stove cool for at least 5 minutes before relighting. Relighting a heated stove can cause large flames that can cause fire, burns, severe injury or death. Never move a burning or hot stove. Always extinguish stove and cool for at least 5 minutes before moving. Moving a burning or hot stove can cause fire, burns, severe injury or death. Never leave a burning or hot stove unattended. An unattended stove can lead to fire and/or a situation where children, pets, or the unwary can be burned, injured, or killed.

6 USE STOVE TO COOK

1. **Set up Windscreen.**
Fold the ends of Windscreen together. Leave a 1-inch (2.5 cm) gap between Windscreen and pot for optimal performance. Ensure that combustion flow and ventilation air are free of any obstruction. Use Windscreen to improve performance in all conditions.
2. **Place pot on stove.**
3. **Maintain Fuel Bottle pressure.**
Add approximately 10 strokes every 10 minutes to maintain performance. Hold Fuel Bottle firmly while pumping.

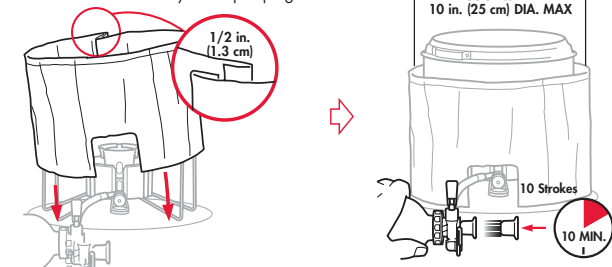

WARNING

Keep fuel bottle away from the stove burner and other heat sources. Position connected fuel bottle so that it is as far away from the burner as possible. Use of bottle near burner or other heat sources can result in the fuel bottle exploding and causing fire, burns, severe injury or death. Never place windscreen around fuel bottle. Never use cookware with a diameter greater than 10 inches (25 centimeters). Never place and operate two or more stoves together. Never operate stove with empty or dry cookware. Never use non-MSR® reflectors or diffusers. Use of stove in any of the preceding manners can result in the fuel bottle exploding and causing fire, burns, severe injury or death. Never use cookware of any size that is ill-suited and/or inappropriate for use with stove, particularly stove pot supports (e.g., cookware with a convex or concave bottom, some enameled cookware, etc.). Use of stove with ill-suited and/or inappropriate cookware can result in cookware and/or stove instability and a situation where hot cookware and/or cookware contents can spill and cause fire, burns, severe injury or death. Cascade Designs, Inc. warrants the use of appropriately sized MSR® brand cookware only use of cookware other than MSR® brand cookware will be at user's own risk and discretion.

7 TURN STOVE OFF

1. **Close Pump Control Valve on Fuel Bottle.**
Residual fuel will continue to burn with a small flame for several minutes.
 2. **Close Flame Adjuster Valve on stove.**
After flames are out, wait 5 minutes for stove to cool.
 3. **Unlock Catch Arm and remove Fuel Line from Pump.**
 4. **Depressurize Fuel Bottle and repack stove.**
Hold the Fuel Bottle upright, away from your face and any sources of heat or ignition. Slowly unscrew Pump to depressurize Fuel Bottle.
- To transport the Fuel Bottle, the Pump may be left inside a depressurized Fuel Bottle. The Pump can also be removed and replaced with the Fuel Bottle Cap.

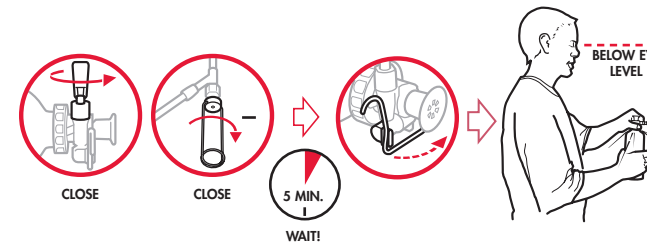

WARNING

Always store fuel bottle with cap securely tightened where it cannot be accessed by children. Storage of fuel bottle with loose cap and/or where accessible by children can result in a child obtaining possession of fuel bottle and accessing bottle contents. Exposure to bottle contents topically and/or by ingestion can cause poisoning, severe injury, or death. Always store fuel bottle in a well-ventilated location away from any possible heat or ignition source such as: water heaters, stoves, pilot lights, or furnaces. Storing bottle near any heat or ignition source can result in the fuel bottle exploding and causing fire, burns, severe injury or death.